

Engineering
PORTFOLIO
2024-2025

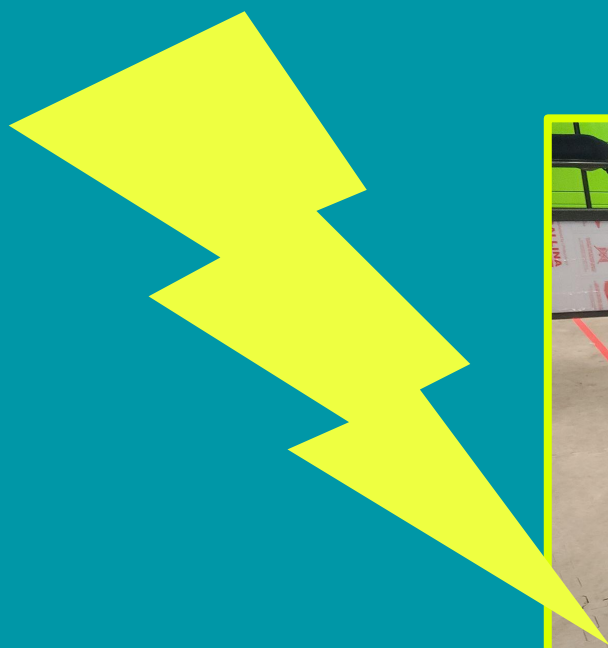

Team Number
27299

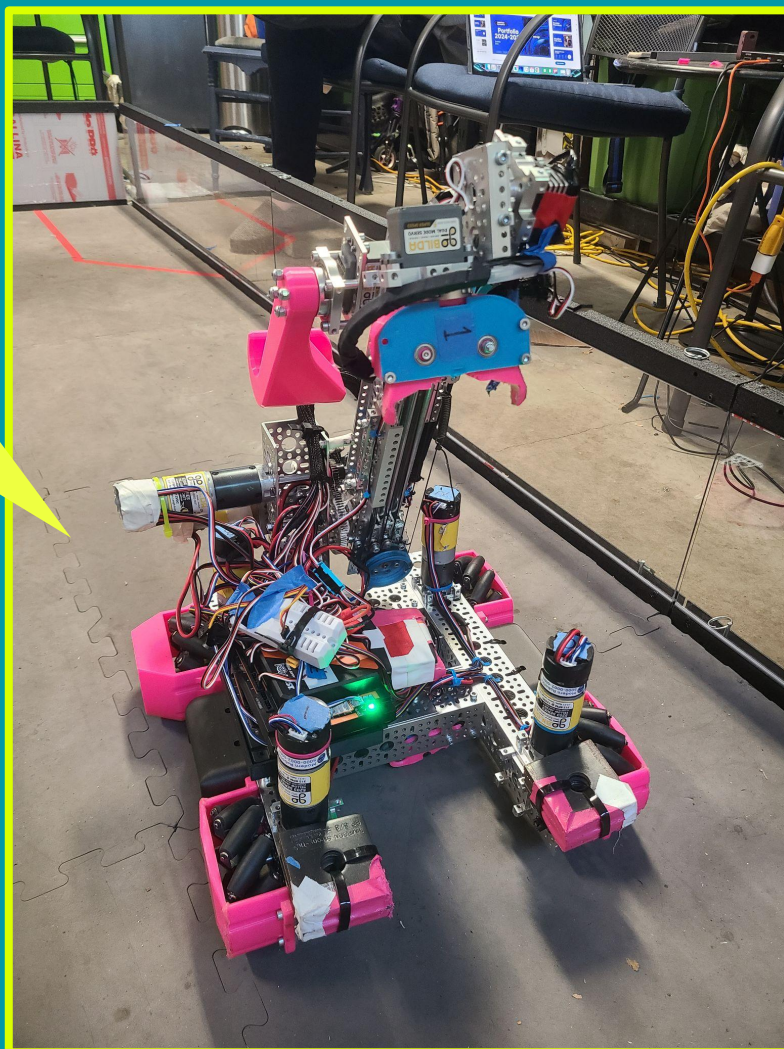

Samotech CYBERQUAKES

SaMoTech Cyber Quakes is a brand-new robotics team under the SaMoTech Robotics community teams. Based in Santa Monica, CA, we are a team of four middle school students competing for the first time in the FIRST Tech Challenge (FTC). As a younger “JV” team to the well-established SaMoTech Robotics, we share the same passion for engineering, coding, and problem-solving.

Though new to FTC, we have achieved incredible success as a new team, demonstrating creativity, determination, and teamwork throughout our season.

Samotech Sponsors



Team Members



Jackson

I am 12 years old, and this is my second year of FTC. I enjoy programming and 3d modeling.



Beckett

I am 14, and this is my first year in FTC. I enjoy swimming.

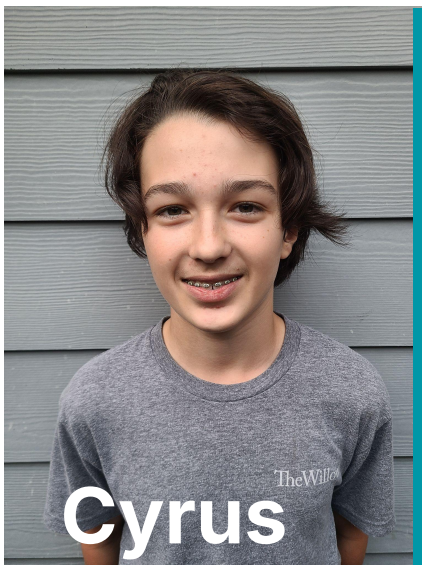

Cyrus

I am 11 years old and this is my first year in FTC. I Enjoy 3D Printing, modeling and building computers.



David

I am twelve years old, this is my first year in FTC. I enjoy Fencing

Our Results

Meets 1-3 Results In 2024-2025

We placed in the top 87% for all teams and 4th in our league.

AVG
score
98

Our averages
score from all
meets is 98
points.

AVG
Auto
22

Our best auto
score was a
64 point
auto.

AVG
69
TELEOP

Our best
Teleop score
was 153.

AVG
10
Endgame

Our average
Endgame
score is 10
points.

Best
Meet
place
2nd



Game Strategy

AUTO

- We use **PedroPathing** for optimal accuracy and speed. We use a website to plan out the paths because PedroPathing is coordinate based.

- 4 Sample auto

Our first auto code scores 4 samples in the high basket. It almost always gets them all, unless we have a mechanical malfunction.

-3 Specimen auto

Our second auto scores 3 specimens on the high bar.

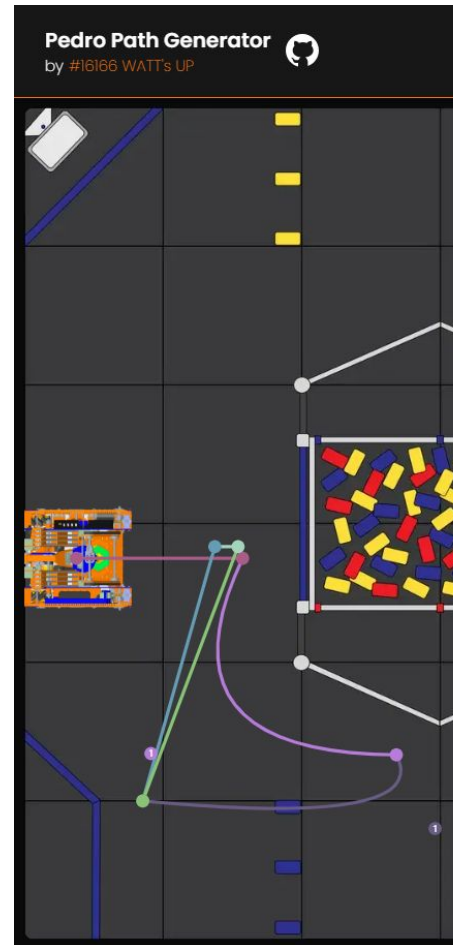

Strategy for Tele-op

Depending on who our alliance partner is we will decide to focus on either specimens or samples. At the beginning of the driver control period, our priority. Our strategy for retrieving samples from the submersible revolves around the fact that **our claw does not need to be accurate to be effective.**

This allows us to go in an area with multiple samples and pick one up with very high likelihood. Once endgame starts we get 1 or 2 objects and then **hang** in the last 5-10 seconds

Match Timeline

Pre-match Coordination

Before the match, we meet with our alliance partner and discuss our strategy for the match. Depending on our alliance partner's capabilities we will do either samples or specimens

2:30
LEFT

AUTONOMOUS

We run either our sample or specimen auto, depending on our teammate's abilities.

2:00
LEFT

TELE-OP

During tele-op, we focus on our decided upon piece, and continue to cycle and score.

0:30
LEFT

ENDGAME

In endgame, we score our last few points, then head over to the submersible to raise ourselves to a level 2 ascent.

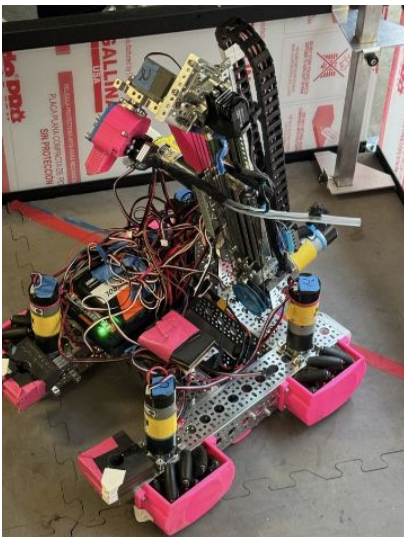

Design: One Arm or Two?

This year's game requires reaching **far** into the pit but also **high** to the bucket. A lot of teams made two slides, one for reaching sideways and one for reaching upwards, but we worried about transferring between claws. So we made an arm that can extend very far but also pivot up and down with gears like a **fire truck with a giant ladder**.



Robot Design: Chassis

- Our chassis is a 4 motor mecanum drive train that allows us to go in any direction. Instead of having the motors hidden in the U-channels we have them vertical to make space for the odometry.
- Odometry - the tiny extra wheels under our robot are like GPS for an FTC field. Auto is very accurate.
- Custom designed and 3D printed wheel fenders protect our wheels from getting trapped over a game piece or getting caught up in the submersible's metal parts.

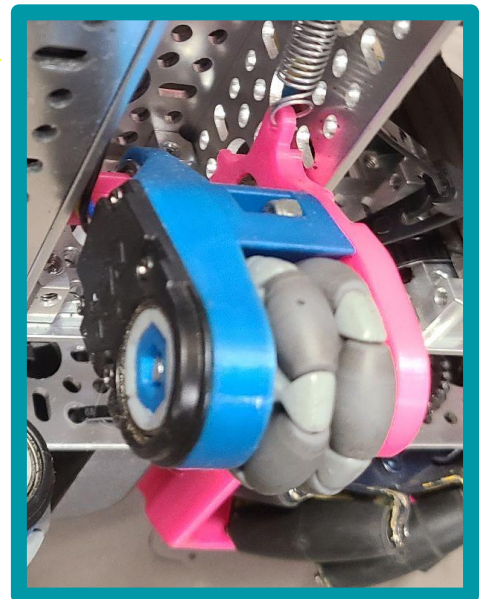
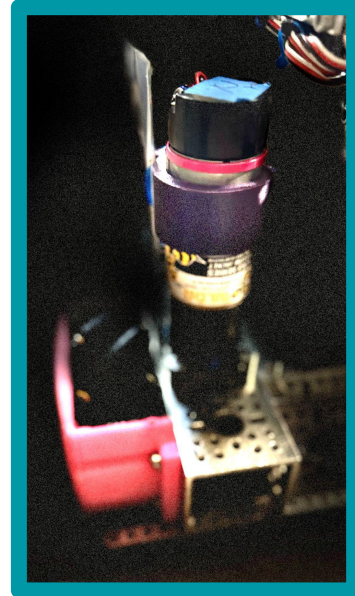

The Arm does it all: Claw + Score + Hang

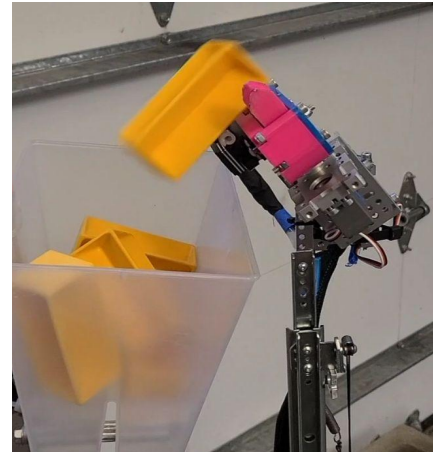

- Our arm is actually a Viper slide that pivots up and down using a motor and gears, from the floor to the high basket. It can reach out at floor level, or score in the high basket.

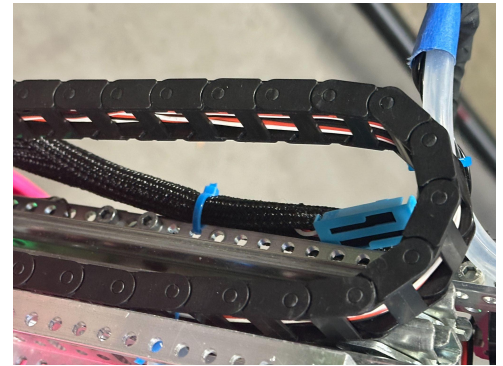

- We use a drag chain (the black thing that looks like a snake) to keep the wires safe and organized as the slide goes in and out.

- Our unique 3D printed hook on the arm allows us to do a stage 2 ascent. The same motor that makes our arm go up and down also lifts us off the ground.

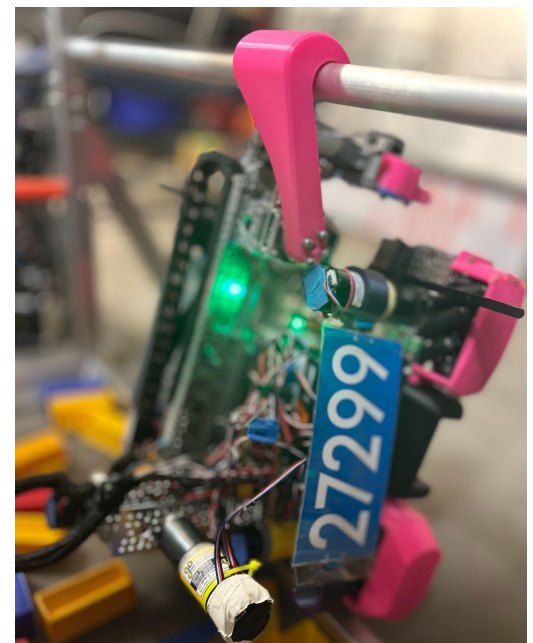

CAD Designs

- Hook, carry handles & Fenders by Beckett
- Open source claw by Seattle Solvers, modified by Jackson
- Robot assembly by Jackson, David, Cyrus & Beckett
- Robot carry handles by Beckett
- Motor clips for signage by Cyrus

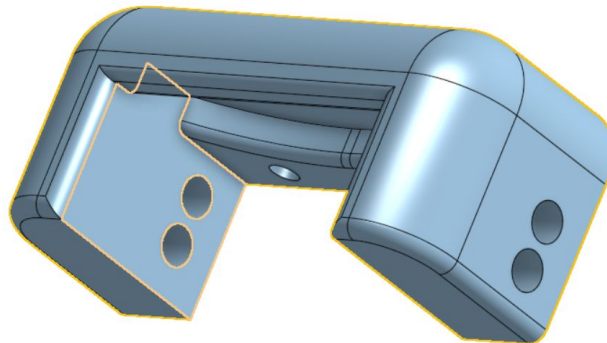
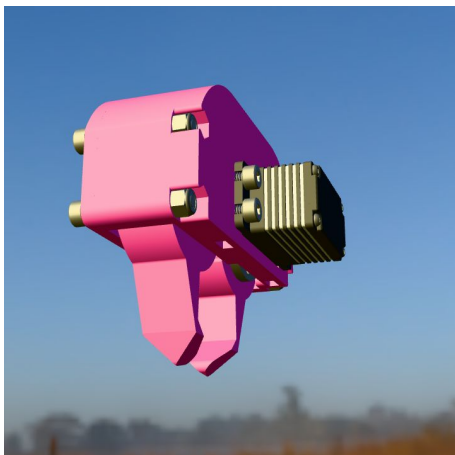
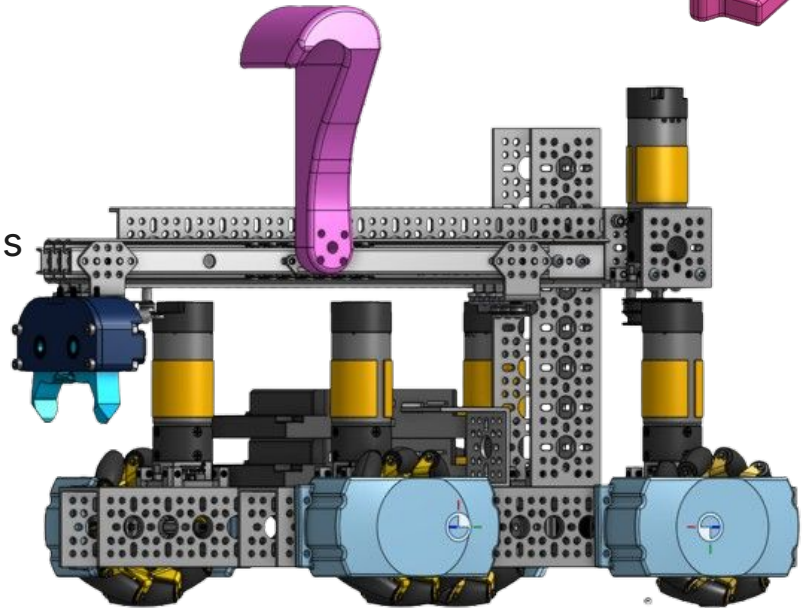
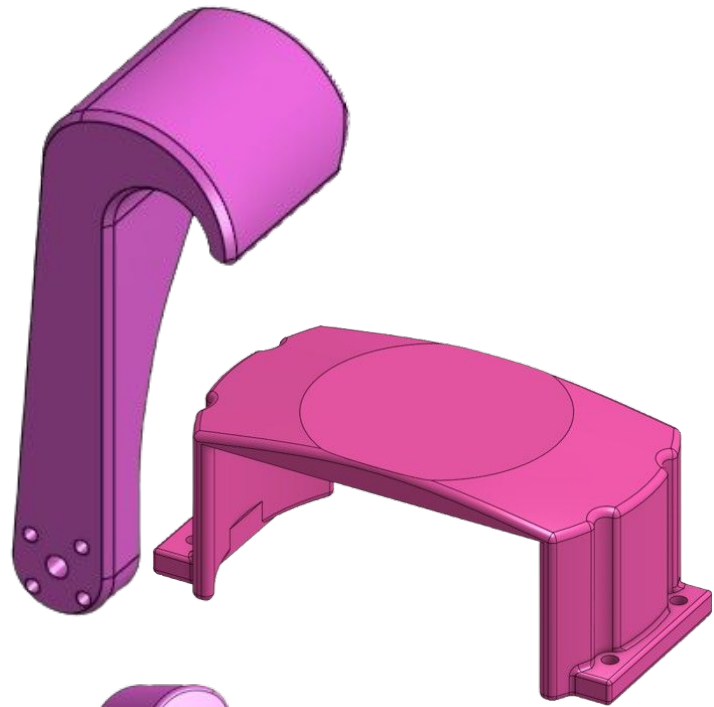

Design Challenges & Solutions

We had some pretty crazy problems this year. For some reason they happened only at meets, and always in the first match of the day so we'd be stuck with it the whole day. I guess we should practice more? We always found a way to fix it next practice, but it has been a stressful learning opportunity! Here are some fun ones:

PROBLEM:	SOLUTION:
<p>Meet 0: The arm is super heavy, so it keeps getting loose and stripping gears right before it falls off.</p>	<p>First, we tried blue loctite, but they still kept coming loose. So we made a checklist of all the bolts to check before each match. That sorta worked.</p>
<p>Meet 1: The arm KEEPS coming loose and falling off!</p>	<p>Sometimes the bolts would STILL come off. So we used Red loctite. Coach says you're not supposed to use red, because apparently it's impossible to get off. But it totally worked and the arm never came off again, but it was indeed impossible to get off later in the season when we needed new gears.</p>
<p>Meet 1: Our hang is crooked because our hook is skinny, so sometimes the refs would give us the ascent and sometimes not.</p>	<p>Design a wider hook. The hook couldn't be in the center of the robot because the arm was. So we made the hook wider to reach towards the center of the bot.</p>
<p>Meet 2: Our arm wouldn't come down after auto, so we were a pushbot during teleop.</p>	<p>Always test your code! We had made a new auto the day before. We didn't realize it messed up the encoders for teleop because we didn't test enough.</p>
<p>Meet 3: Our arm fell off AGAIN, but in a different way than it used to! This time one of the stages of the slides just came apart in auto, and the robot drags the arm around by the wires. No points for you!</p>	<p>We needed new slides, but didn't have time to do major surgery. For the rest of our matches, we made a plan for what to do that match depending on if/when in the match our arm falls off again. We replaced the slides after that and realized we had put in one backwards at the start of the season. :(</p>